

SECTION A-A

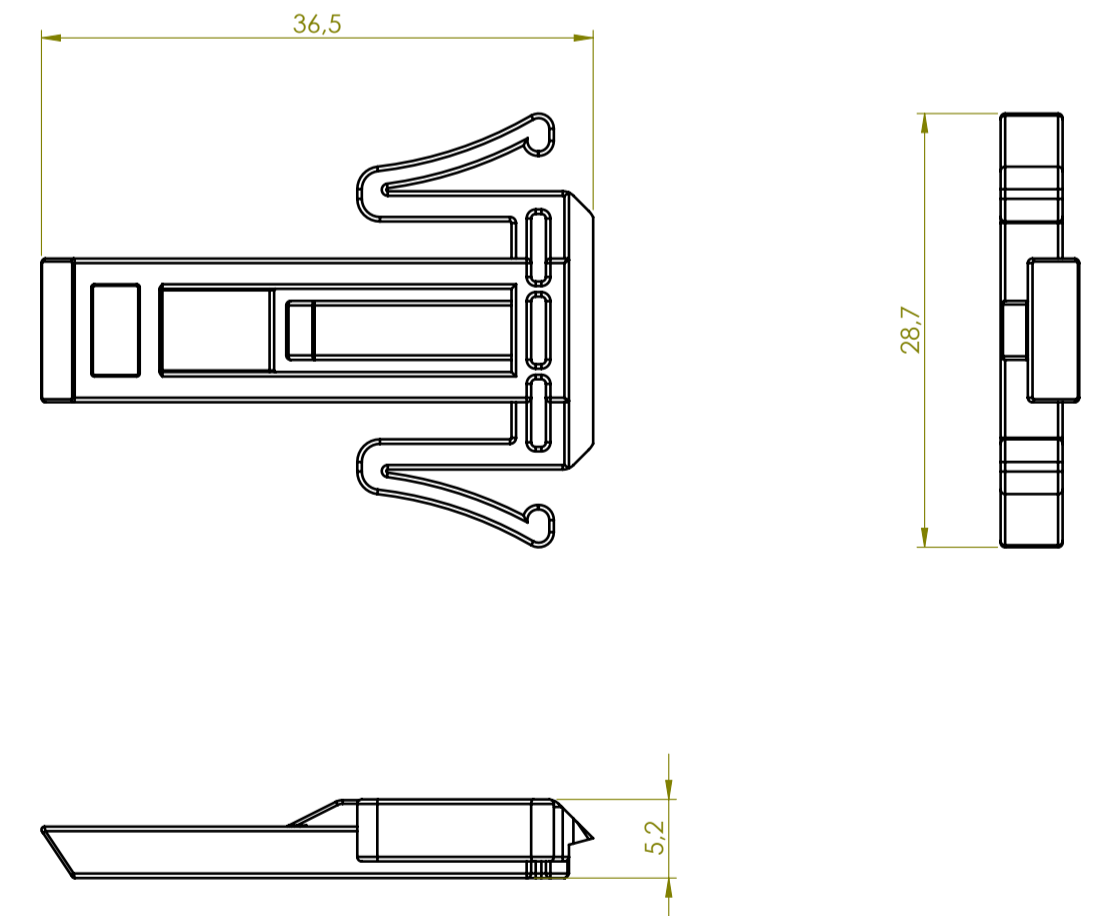
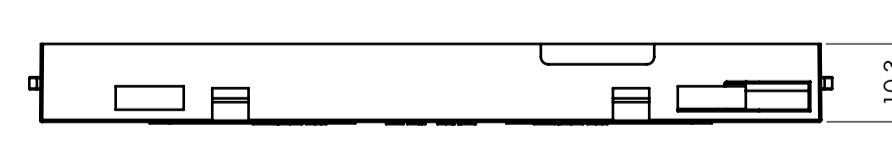
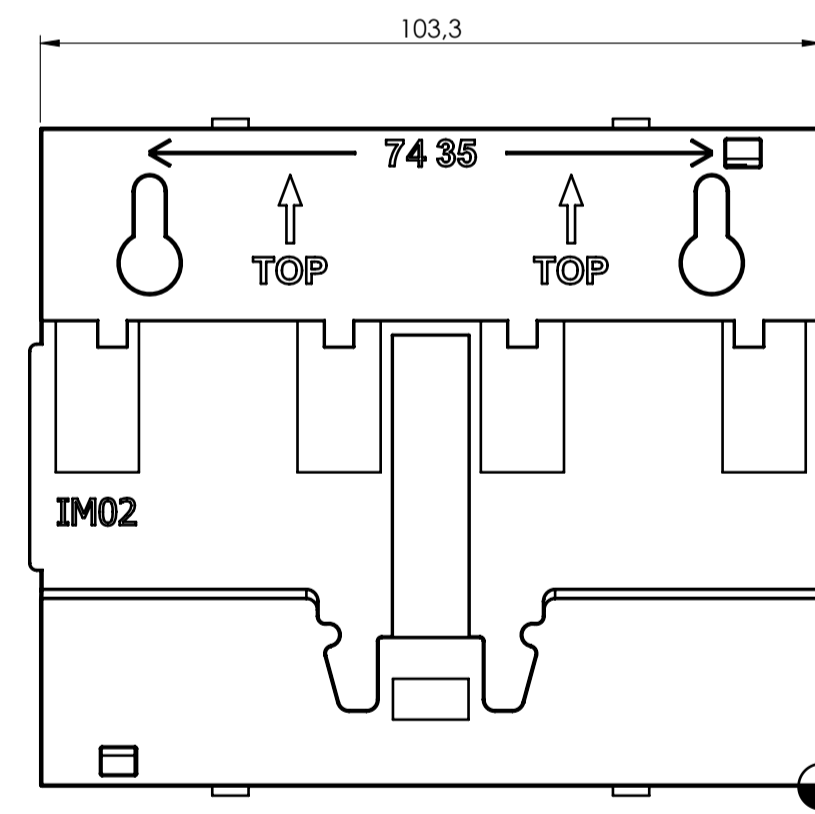
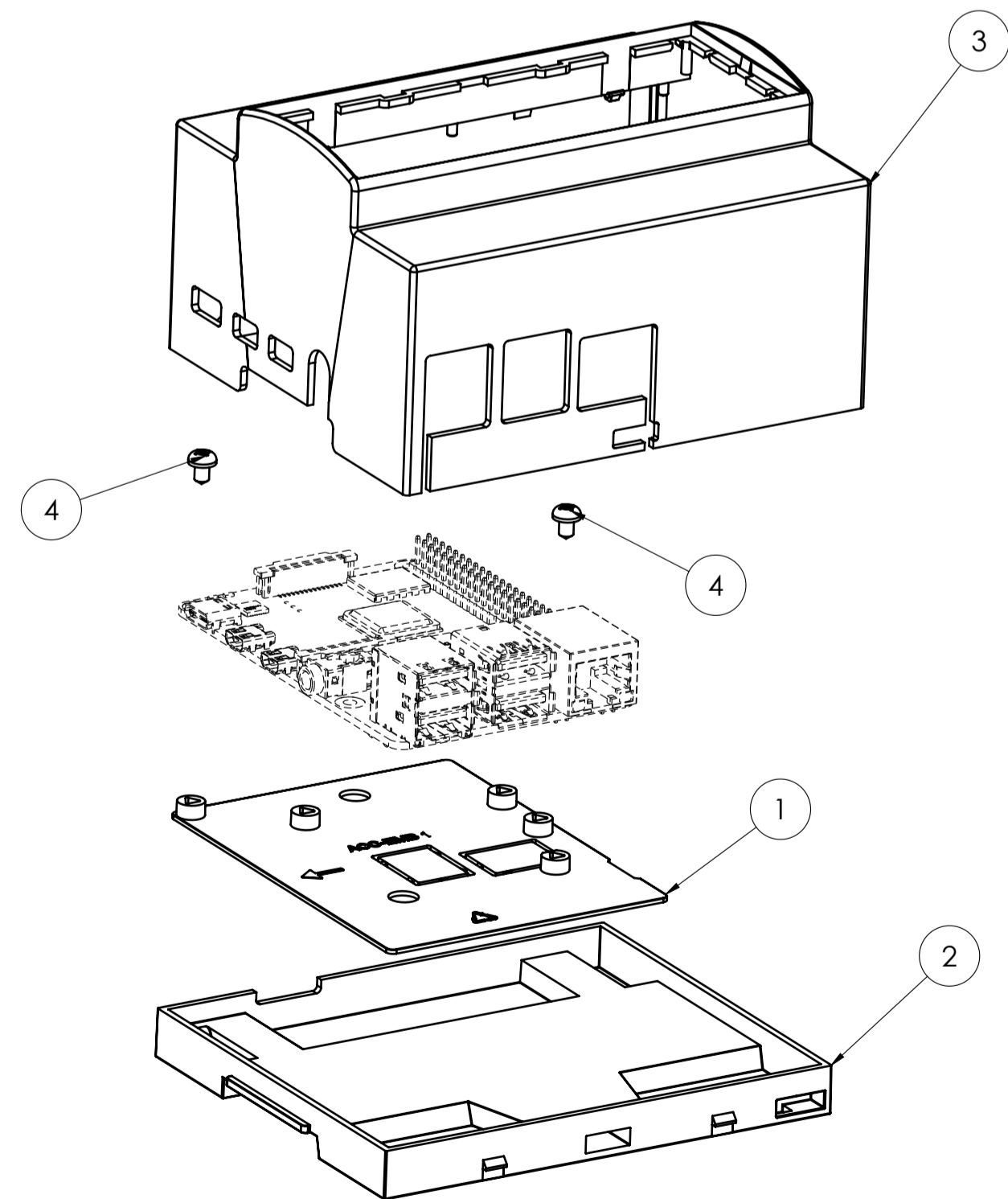
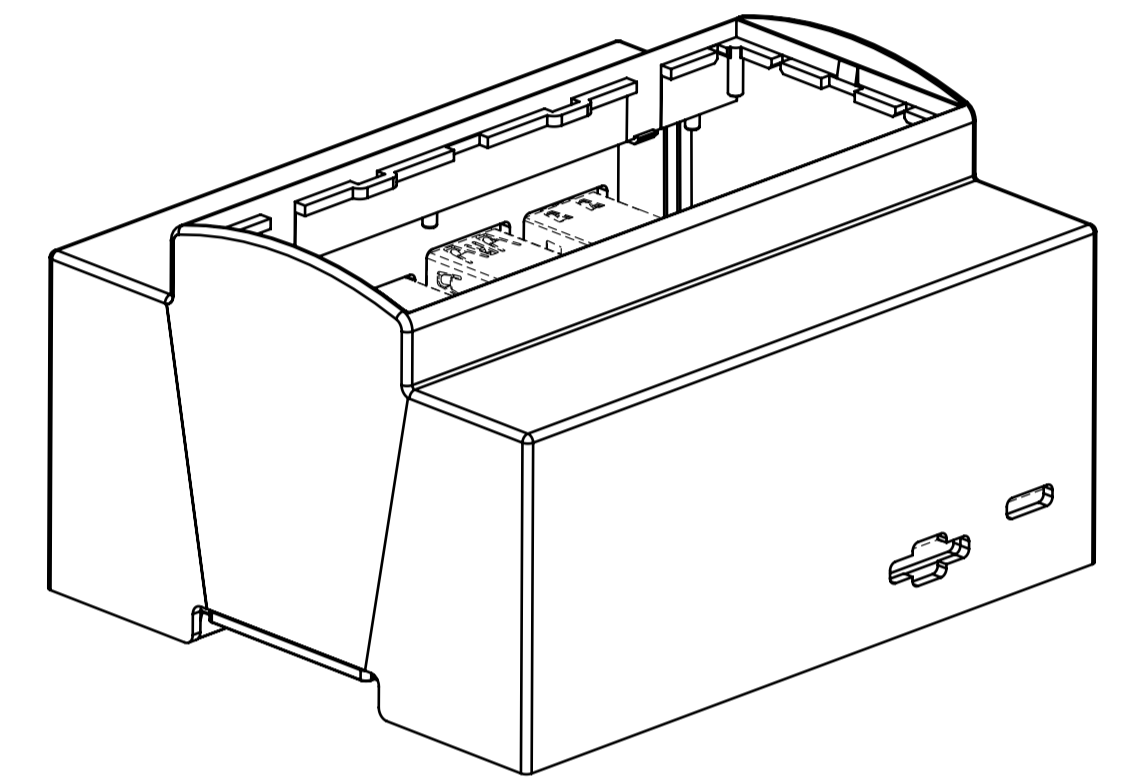
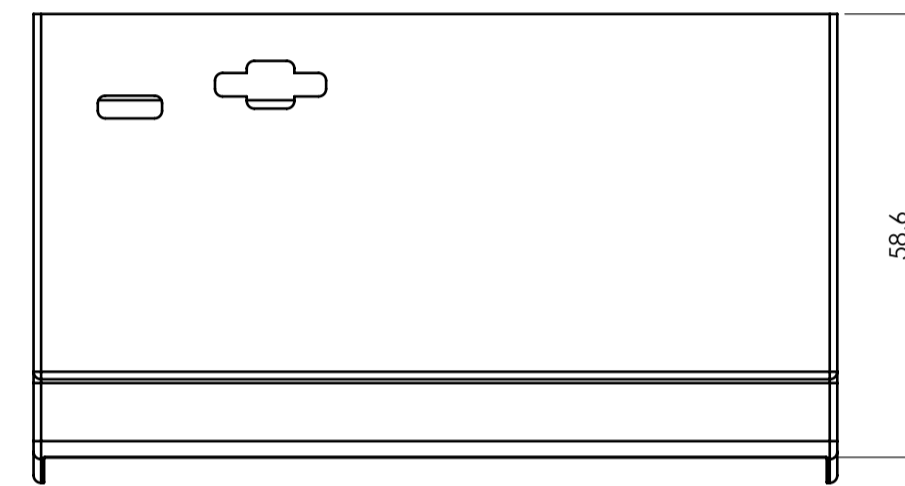
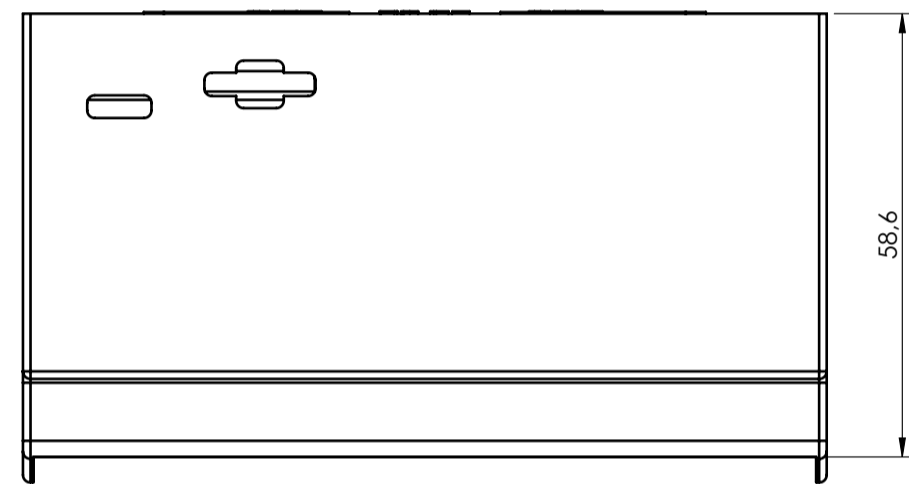
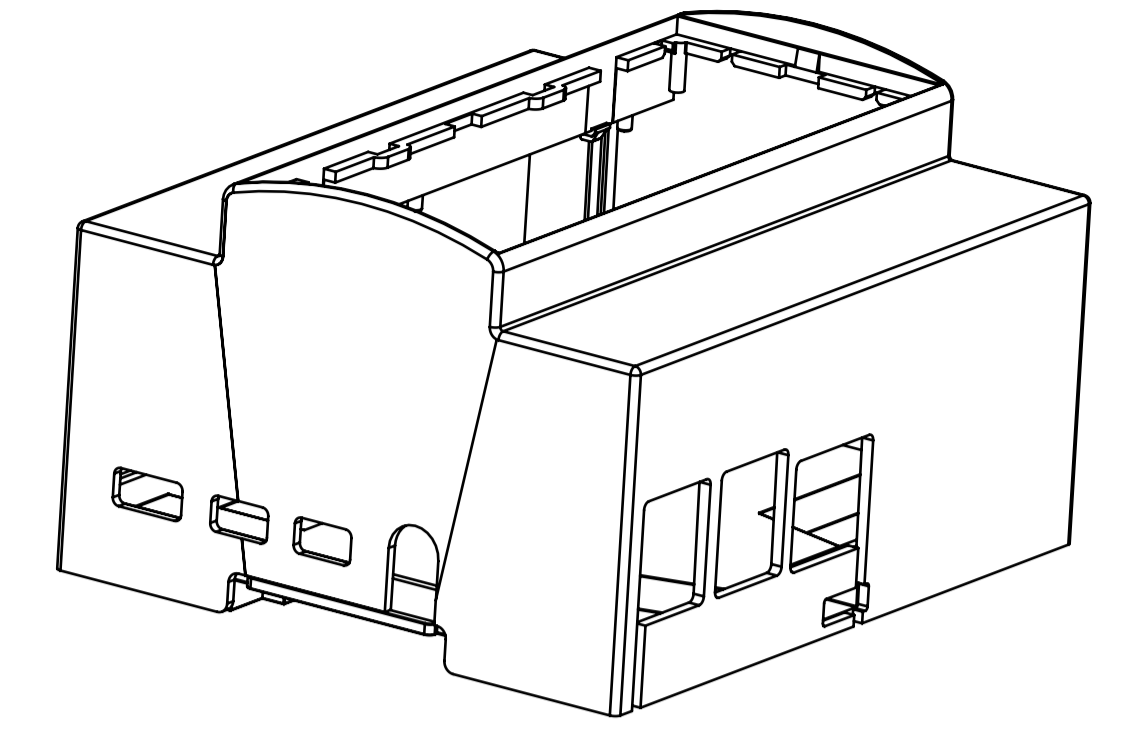
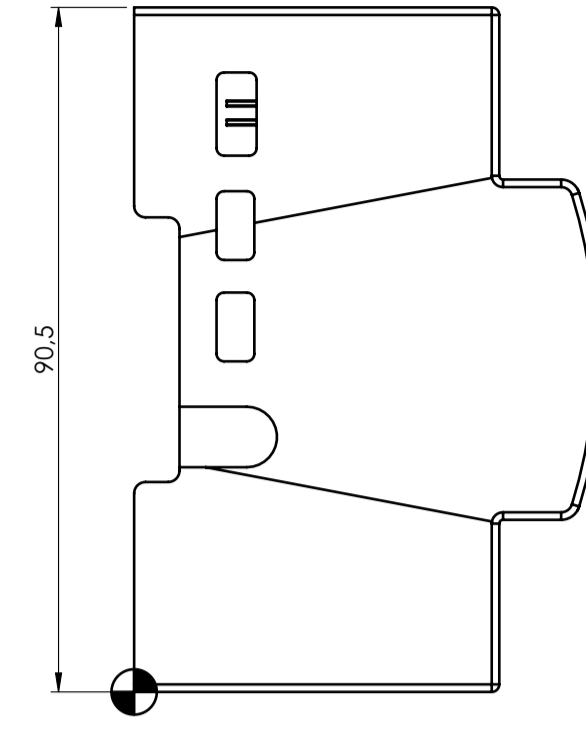
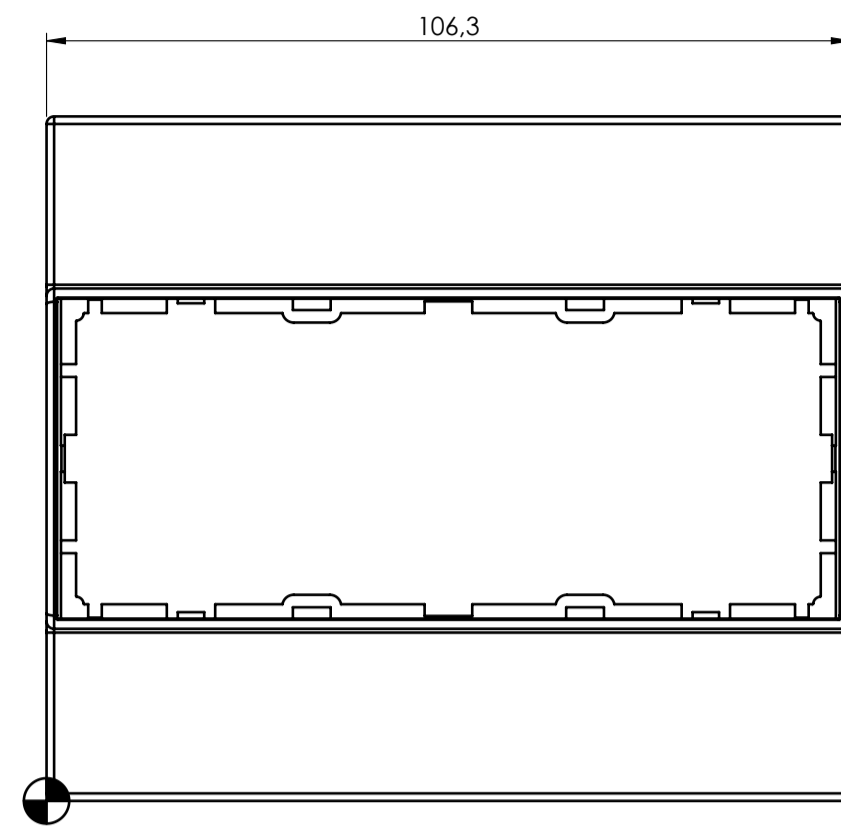

General information:  
 - Workpiece zero point for mechanical processing  
 - Minimum recommended radius for machining = R1.0 mm  
 - Mounting rail like EN 60715: TH 35-7.5 or TH 35-15  
 - Recommended PCB outline on [www.italtronic.com](http://www.italtronic.com)

RIF.	Q.TY	DRAWING	DESCRIPTION
1	1	2_050_00001	ACCESSORY FOR BASE EMBEDDED EMB1
2	1	2_050_00029	BASE 6M XT RASPBERRY B+/3 FOR BASE EMBEDDED ACCESSORY
3	1	2_050_00028	BODY ENCLOSURE 6M XTS RASPBERRY Pi4
4	2	8_100_00013	SCREW 2.9 X 4.5 TC +

General Tolerance 198 EN 22768/1 Media [m]				Sheet:								
from 0.5 to 3	from 3 to 6	from 6 to 30	from 30 to 120	from 120 to 400								
±0.1	±0.1	±0.2	±0.3	±0.5	1							
Scale:	1:1	IM:	Drawn:	M.S.	Checked:	R.N.	Date:	10/01/2024	Material:		Process:	
Dimension in mm												
Description:		KIT 6M XTS RASPBERRY Pi 4		KIT 6M XTS RASPBERRY Pi 4		Drawing ref:		3_050_00032		Rev.:		-
italtronic		enclosures for electronics		italtronic.com								A1